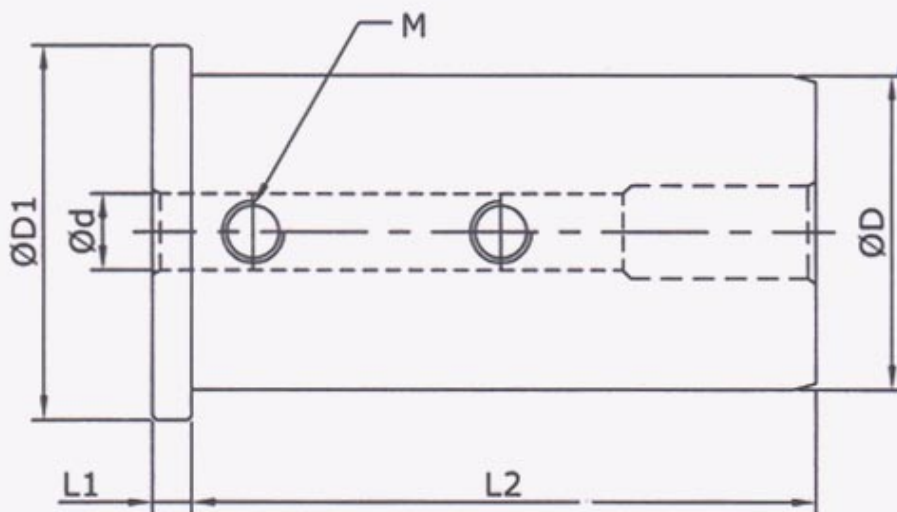

**FIG. 1**



**FIG. 2**

## Description

Universal Model Turret Sleeve suitable for any make of Turret

Tool Locking for Fig. 1 type of Turret sleeve is by the grub of the Turret Block which locks both the Turret Sleeve as well as the Tool.

Suitable to hold Cylindrical Shank Tools (Eg. Boring Tool Holder) on Turret of CNC Lathe.

Part No.	OD ØD mm	Bore Ød mm	ØD1 mm	W mm	L1 mm	L2 mm	L3 mm	L4 mm	M Thread
TSL 16X8	16	8	22	-	5	40	-	-	M4
TSL 16X10	16	10	22	7	5	40	32	3	-

Part No.	OD ØD mm	Bore Ød mm	ØD1 mm	W mm	L1 mm	L2 mm	L3 mm	L4 mm	M Thread
TSL 20X8	20	8	26	-	5	50	-	-	M5
TSL 20X10	20	10	26	-	5	50	-	-	M5
TSL 20X12	20	12	26	9	5	50	42	3	-
TSL 25X6	25	6	32	-	5	50	-	-	M5
TSL 25X8	25	8	32	-	5	50	-	-	M6
TSL 25X10	25	10	32	-	5	50	-	-	M6
TSL 25X12	25	12	32	-	5	50	-	-	M6
TSL 25X16	25	16	32	10	5	50	42	3	-
TSL 32X6	32	6	38	-	5	60	-	-	M5
TSL 32X8	32	8	38	-	5	60	-	-	M6
TSL 32X10	32	10	38	-	5	60	-	-	M8
TSL 32X12	32	12	38	-	5	60	-	-	M8
TSL 32X16	32	16	38	10	5	60	52	3	-
TSL 32X20	32	20	38	10	5	60	52	3	-
TSL 32X25	32	25	38	10	5	60	52	3	-
TSL 40X6	40	6	48	-	5	85	-	-	M5
TSL 40X8	40	8	48	-	5	85	-	-	M6
TSL 40X10	40	10	48	-	5	85	-	-	M8
TSL 40X12	40	12	48	-	5	85	-	-	M8
TSL 40X16	40	16	48	12	5	85	77	2	-
TSL 40X20	40	20	48	12	5	85	77	2	-
TSL 40X25	40	25	48	12	5	85	77	2	-
TSL 40X32	40	32	48	12	5	85	77	2	-
TSL 50X10	50	10	60	-	8	92	-	-	M8
TSL 50X12	50	12	60	-	8	92	-	-	M8
TSL 50X16	50	16	60	12	8	92	80	4	-
TSL 50X20	50	20	60	12	8	92	80	4	-
TSL 50X25	50	25	60	12	8	92	80	4	-
TSL 50X32	50	32	60	12	8	92	80	4	-
TSL 50X40	50	40	60	12	8	92	80	4	-