



**REVOLVING CENTERS & CNC TOOL HOLDERS**



**Turnmax Machine Tools is OEM Supplier to all CNC Lathe manufacturers of India Including :**

- **ACE Designers**
- **Bharat Fritz Werner (BFW)**
- **Lakshmi Machine Works (LMW)**
- **Jyoti CNC Automation**
- **Macpower CNC Machines**
- **Lokesh Machines**
- **Galaxy Machinery**
- **PMT Machines**
- **Electronica Hi-Tech Machine Tools**
- **Yamazaki Mazak India**
- **Pride Machine Tools**
- **Grind Master Machines**
- **Global CNC Automation**
- **S&T Machinery (STM)**
- **Batliboi**
- **Askar Microns**
- **Sands Precision**
- **Hi-Life Machine Tools**
- **HMT Machine Tools**
- **Marshall Machines**
- **Tussor Machine Tools(Pinacho)**

- **India's largest & No. 1 Revolving Center manufacturing co.**
- **Exported to more than 16 countries**
- **OEM for all CNC Lathe Manufacturers**
- **Quality comparable with best European makes of Germany & Italy**

# EXPORTED TO :



- USA
- UK
- Malaysia
- Netherlands
- Czech Republic
- Chile
- Italy
- Iran
- Belgium
- Australia
- New Zealand
- South Africa
- Mexico
- Israel
- Thailand
- Canada
- Argentina
- UAE



AN ISO 9001 : 2015  
CERTIFIED COMPANY

## COMPANY PROFILE

The company **TURNMAX MACHINE TOOLS** was established primarily to cater to the needs of the various Machine Tool manufacturers of India as an OE supply company.

The initial products that were manufactured were the Revolving Centers and various types of CNC Tool Holders. In a short period of time these products got approval and acceptance from almost all leading Indian Machine Tool Manufacturers including ACE Designers – which is the largest Indian CNC manufacturer.

We also now have exports to more than 16 countries.

A distinguishing feature about our company is that we have abstained from getting any of our products sub-contracted and branding them with our brand. All products are made in house.

We have installed sophisticated machinery in our factory and continue to invest in latest machinery and equipment. A team of highly dedicated and competent personnel is at the helm lead by technocrat trained in advanced foreign country.

Since inception our quality policy has been very clear – to offer maximum value to customers for their money by offering consistent precise quality and by designing tooling to suit specific job requirements.

It is due to this that today we are India's No.1 company manufacturing Revolving Centers – both for quality and quantity produced.

We take this opportunity to express our sincere thanks to all companies and customers who have reposed their faith in our company and products and have helped us reach where we are today.

# REVOLVING CENTER CNC HEAVY DUTY - R MODEL STUB POINT

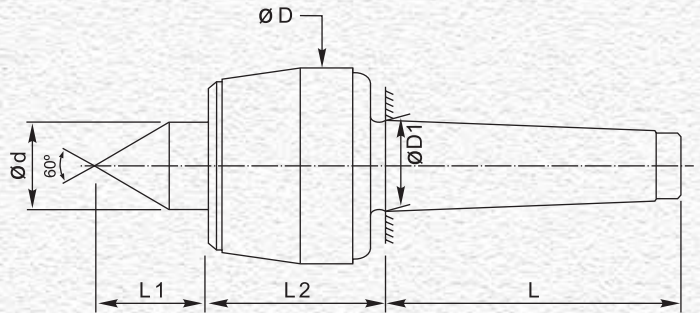

Part No.	Shank Taper	Point Style	Ød mm	ØD mm	ØD1 mm	L1 mm	L2 mm	L mm	Max. Job Wt. Kg.	Conc. Error mm	Max. RPM
HSC MT2 CNC HDRS	MT-2	Stub Point	20	46	17.780	25.0	48.5	64.0	200	0.005	7000
HSC MT3 CNC HDRS	MT-3	Stub Point	28	62	23.825	34.0	62.5	81.0	500	0.005	5000
HSC MT4 CNC HDRS	MT-4	Stub Point	32	68	31.267	41.0	65.0	102.5	800	0.005	3800
HSC MT5 CNC HDRS	MT-5	Stub Point	38	87	44.399	51.0	80.5	129.5	2000	0.005	3000
HSC MT6 CNC HDRS	MT-6	Stub Point	55	112	63.348	63.0	106.0	182	3500	0.010	2600

# REVOLVING CENTER CNC HEAVY DUTY - R MODEL EXTENDED POINT

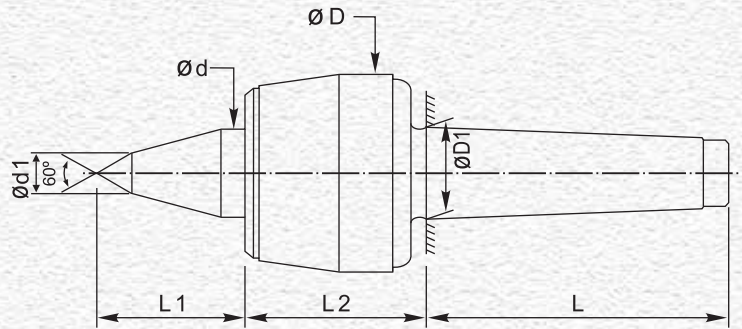

Part No.	Shank Taper	Point Style	Ød1 mm	Ød mm	ØD mm	ØD1 mm	L1 mm	L2 mm	L mm	Max. Job Wt. Kg.	Conc. Error mm	Max. RPM
HSC MT2 CNC HDRE	MT-2	Extended Point	10	20	46	17.780	35.0	48.5	64.0	140	0.005	7000
HSC MT3 CNC HDRE	MT-3	Extended Point	12	28	62	23.825	51.0	62.5	81.0	400	0.005	5000
HSC MT4 CNC HDRE	MT-4	Extended Point	14	32	68	31.267	54.5	65.0	102.5	500	0.005	3800
HSC MT5 CNC HDRE	MT-5	Extended Point	16	38	87	44.399	65.0	80.5	129.5	1200	0.005	3000
HSC MT6 CNC HDRE	MT-6	Extended Point	18	55	112	63.348	95.0	106.0	182.0	2500	0.010	2600

# REVOLVING CENTER CNC HEAVY DUTY - R MODEL PROFILED POINT

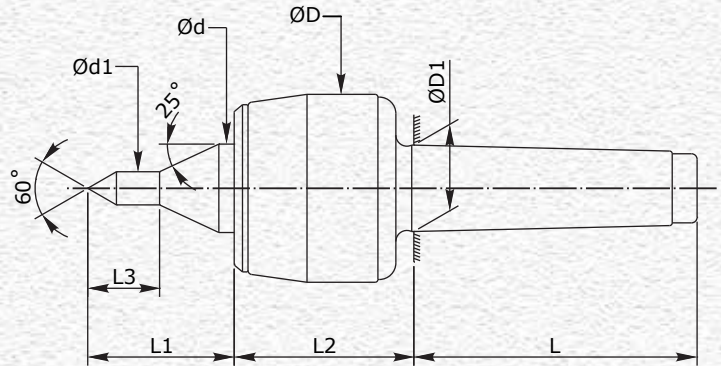

Part No.	Shank Taper	Point Style	Ød mm	Ød1 mm	ØD mm	ØD1 mm	L1 mm	L2 mm	L3 mm	L mm	Max. Job Wt. Kg.	Conc. Error mm	Max. RPM
HSC MT2 CNC HDRP	MT-2	Profiled Point	20	8	46	17.780	35.0	48.5	16	64.0	100	0.005	7000
HSC MT3 CNC HDRP	MT-3	Profiled Point	28	10	62	23.825	47.0	62.5	20	81.0	150	0.005	5000
HSC MT4 CNC HDRP	MT-4	Profiled Point	32	12	68	31.267	53.0	65.0	26	102.5	180	0.005	3800
HSC MT5 CNC HDRP	MT-5	Profiled Point	38	14	87	44.399	65.0	80.5	30	129.5	280	0.005	3000

# REVOLVING CENTER CNC HEAVY DUTY - R MODEL INTERCHANGEABLE STUB POINT

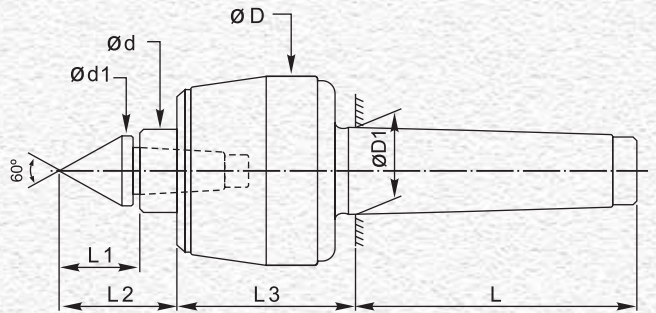

Part No.	Shank Taper	Point Style	Internal Female Style	Ød mm	Ød1 mm	ØD mm	ØD1 mm	L1 mm	L2 mm	L3 mm	L mm	Max. Job Wt. kg.	Conc. Error mm	Max. RPM
HSC MT3 CNC HDR INTS	MT-3	Stub Point	1:10	28	24	62	23.825	28.0	38.0	62.5	81.0	150	0.010	5000
HSC MT4 CNC HDR INTS	MT-4	Stub Point	1:10	32	28	68	31.267	32.5	42.5	65.0	102.5	250	0.010	3800
HSC MT5 CNC HDR INTS	MT-5	Stub Point	1:10	38	34	87	44.399	41.0	51.0	80.5	129.5	650	0.010	3000



# REVOLVING CENTER CNC HEAVY DUTY - R MODEL INTERCHANGEABLE EXTENDED POINT

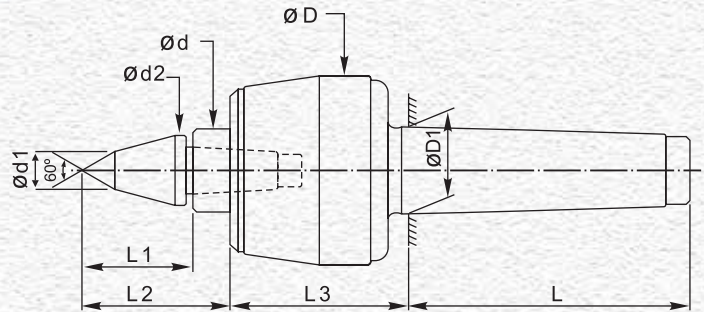

Part No.	Shank Taper	Point Style	Internal Female Style	Ød mm	Ød1 mm	Ød2 mm	ØD mm	ØD1 mm	L1 mm	L2 mm	L3 mm	L mm	Max. Job Wt. kg.	Conc. Error mm	Max. RPM
HSC MT3 CNC HDR INTE	MT-3	Extended Point	1:10	28	12	22	62	23.825	36.5	46.5	62.5	81.0	100	0.010	5000
HSC MT4 CNC HDR INTE	MT-4	Extended Point	1:10	32	14	26	68	31.267	42.5	52.5	65.0	102.5	200	0.010	3800
HSC MT5 CNC HDR INTE	MT-5	Extended Point	1:10	38	16	32	87	44.399	52.0	62.0	80.5	129.5	400	0.010	3000

# REVOLVING CENTER CNC HEAVY DUTY - R MODEL INTERCHANGEABLE PROFILED POINT

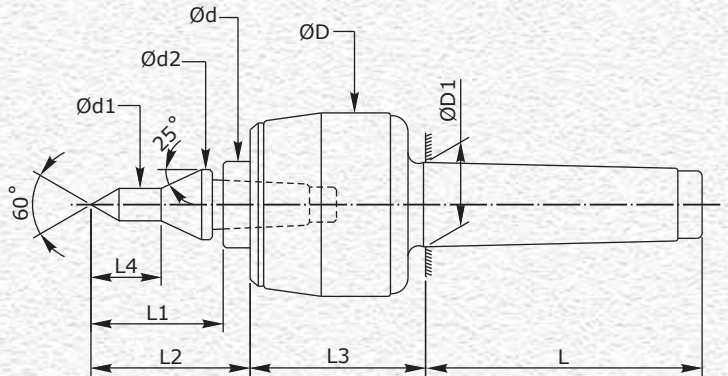

Part No.	Shank Taper	Internal Female Taper	Ød mm	Ød1 mm	Ød2 mm	ØD mm	ØD1 mm	L1 mm	L2 mm	L3 mm	L4 mm	L mm	Max. Job Wt. Kg.	Conc. Error mm	Max. RPM
HSC MT3 CNC HDRP	MT-3	1:10	28	10	22	62	23.825	40	50	62.5	20	81	50	0.010	5000
HSC MT4 CNC HDRP	MT-4	1:10	32	12	26	68	31.267	49	59	65.0	26	102.5	125	0.010	3800
HSC MT5 CNC HDRP	MT-5	1:10	38	14	32	87	44.399	57	67	80.5	30	129.5	200	0.010	3000

Also Available in  
CNC HEAVY DUTY - R MODEL



Carbide Tipped  
Stub Point



Carbide Tipped  
Extended Point



With Draw off Nut  
Stub Point



With Draw off Nut  
Extended Point



With Draw off Nut  
Carbide Tipped  
Stub Point



With Draw off Nut  
Carbide Tipped  
Extended Point

# REVOLVING CENTER CNC MEDIUM DUTY SMALL CASING DIAMETER STUB POINT

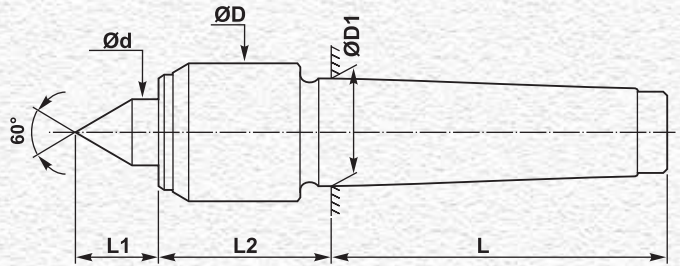

Part No.	Shank Taper	Point Style	$\varnothing d$ mm	$\varnothing D$ mm	$\varnothing D1$ mm	L1 mm	L2 mm	L mm	Max. Job Wt. Kg.	Conc. Error mm	Max. RPM
HSC MT2 CNC MD SCS	MT-2	Stub Point	15	34	17.780	19	45.5	64.0	200	0.005	7000
HSC MT3 CNC MD SCS	MT-3	Stub Point	15	34	23.825	19	45.5	81.0	400	0.005	7000
HSC MT4 CNC MD SCS	MT-4	Stub Point	20	42	31.267	25	53.5	102.5	800	0.005	6300
HSC MT5 CNC MD SCS	MT-5	Stub Point	32	68	44.399	41	76.5	129.5	1600	0.010	4300
HSC MT6 CNC MD SCS	MT-6	Stub Point	50	102	63.348	58	104.0	182.0	3500	0.020	3000

\* Suitable for light & medium duty load applications only at high rpm. Not suitable for heavy load applications.

\* For heavy duty load applications use CNC Heavy Duty R Model.

# REVOLVING CENTER CNC MEDIUM DUTY SLIMLINE STUB POINT

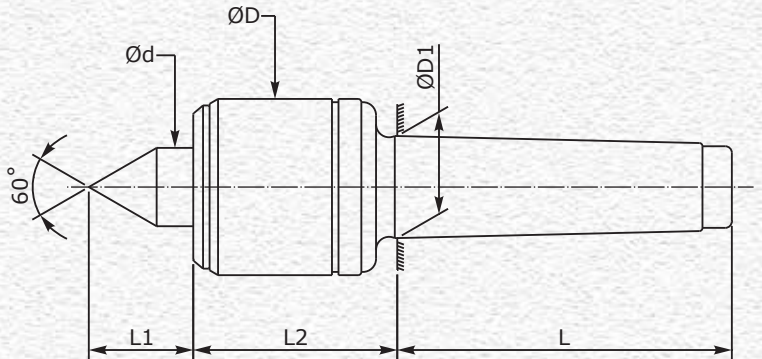

Part No.	Shank Taper	Point Style	Ød mm	ØD mm	ØD1 mm	L1 mm	L2 mm	L mm	Max. Job Wt. Kg.	Conc. Error mm	Max. RPM
HSC MT3 CNC MD SLS	MT-3	Stub Point	20.0	42	23.825	26	52.0	81.0	450	0.005	6300
HSC MT4 CNC MD SLS	MT-4	Stub Point	24.0	54	31.267	32	63.0	102.5	800	0.005	4500
HSC MT5 CNC MD SLS	MT-5	Stub Point	38.0	87	44.399	51	91.5	129.5	2000	0.010	2800
HSC MT6 CNC MD SLS	MT-6	Stub Point	59.5	125	63.348	68	107.5	182	5000	0.020	1900

Also Available in  
**CNC MEDIUM DUTY  
SMALL CASING DIAMETER**



Extended Point



Profiled Point

Also Available in  
**CNC MEDIUM DUTY  
SLIMLINE**



Extended Point



Profiled Point

# REVOLVING CENTER STANDARD

(For Conventional Slow Speed  
Non CNC application.  
Not recommended for Heavy  
Duty Application)

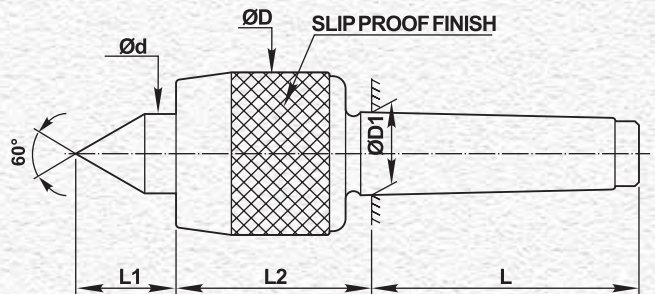

Part No.	Model	Shank Taper	$\varnothing d$ mm	$\varnothing D$ mm	$\varnothing D_1$ mm	L1 mm	L2 mm	L mm	Max. Job Wt. Kg.	Conc. Error mm
RC MT1 STD	Standard	MT-1	18.0	46.5	12.065	26.0	51.5	53.5	25	0.015
RC MT2 STD	Standard	MT-2	23.0	50.0	17.780	31.0	59.0	64.0	50	0.015
RC MT3 STD	Standard	MT-3	30.0	62.0	23.825	38.0	68.5	81.0	75	0.015
RC MT4 STD	Standard	MT-4	30.0	62.0	31.267	38.0	71.0	102.5	100	0.015
RC MT5 STD	Standard	MT-5	34.0	68.0	44.399	42.0	75.5	129.5	150	0.015
RC MT6 STD	Standard	MT-6	50.0	105.0	63.348	58.0	91.0	182.0	200	0.015

Also Available as Carbide Tipped & Female.

# REVOLVING CENTER EXTRA HEAVY DUTY

(For Conventional Slow Speed  
Non CNC application.  
For Heavy Duty Turning Application)

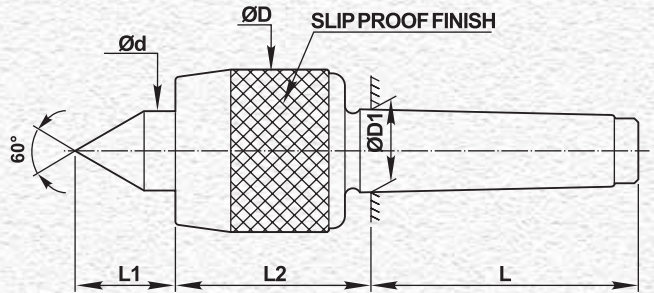

Part No.	Model	Shank Taper	Ød mm	ØD mm	ØD1 mm	L1 mm	L2 mm	L mm	Max. Job Wt. Kg.	Conc. Error mm
RC MT3 EXHD	Extra Heavy Duty	MT-3	28.0	63.0	23.825	38.0	66.5	81.0	350	0.015
RC MT4 EXHD	Extra Heavy Duty	MT-4	32.0	68.0	31.267	40.0	71.5	102.5	500	0.015
RC MT5 EXHD	Extra Heavy Duty	MT-5	38.0	78.0	44.399	45.0	78.0	129.5	1250	0.015
RC MT6 EXHD	Extra Heavy Duty	MT-6	55.0	125.0	63.348	63.0	88.0	182.0	2000	0.015

Also Available as Carbide Tipped



# REVOLVING CENTER SUPER EXTRA HEAVY DUTY

(For Conventional Slow Speed  
Application. Heavier Design  
compared to Extra Heavy Duty Model)

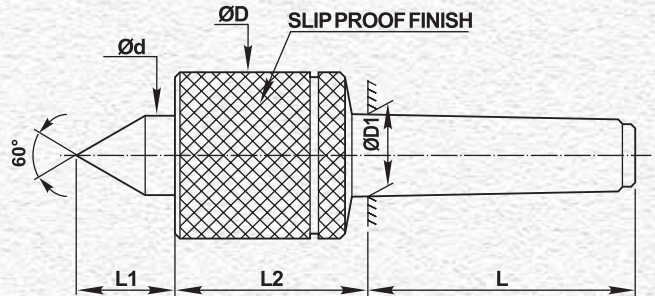

Part No.	Model	Shank Taper	Ød mm	ØD mm	ØD1 mm	L1 mm	L2 mm	L mm	Max. Job Wt. Kg.	Conc. Error mm
RC MT4 SEXHD	Super Extra Heavy Duty	MT-4	38.0	78.0	31.267	45.0	81.5	102.5	1000	0.015
RC MT5 SEXHD	Super Extra Heavy Duty	MT-5	46.0	102.0	44.399	52.0	91.5	129.5	1750	0.015
RC MT6 SEXHDC	Super Extra Heavy Duty Compact	MT-6	65.0	140.0	63.348	71.0	109.0	182.0	4000	0.015
RC MT7 SEXHD	Super Extra Heavy Duty	MT-7	72.0	155.0	83.058	77.0	144.5	254.0	5000	0.015

# REVOLVING CENTER JUMBO HEAVY DUTY - COMPACT

(Heaviest Design)

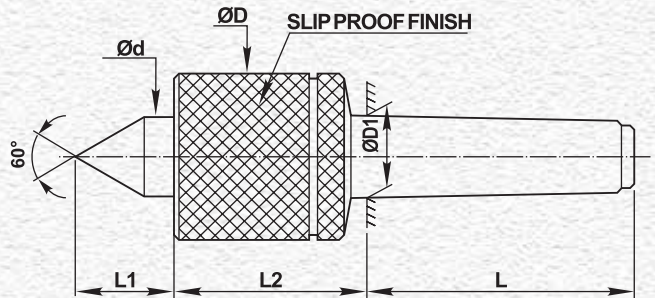

Part No.	Model	Shank Taper	Ød mm	ØD mm	ØD1 mm	L1 mm	L2 mm	L mm	Max. Job Wt. Kg.	Conc. Error mm
RC MT5 JHDC	Jumbo Heavy Duty Compact	MT-5	55.0	125.0	44.399	63.0	92.5	129.5	2500	0.015
RC MT6 JHDC	Jumbo Heavy Duty Compact *	MT-6	74.0	180.0	63.348	82.0	112.0	182.0	5000	0.015
RC MT7 JHDC	Jumbo Heavy Duty Compact *	MT-7	74.0	180.0	83.058	82.0	112.0	254.0	6500	0.015

\* Draw off Nut supplied as standard.

# CNC PIPE CENTER - BLUNT

## 60° Angle Revolving Cone (Not Dead)

With Draw off Nut

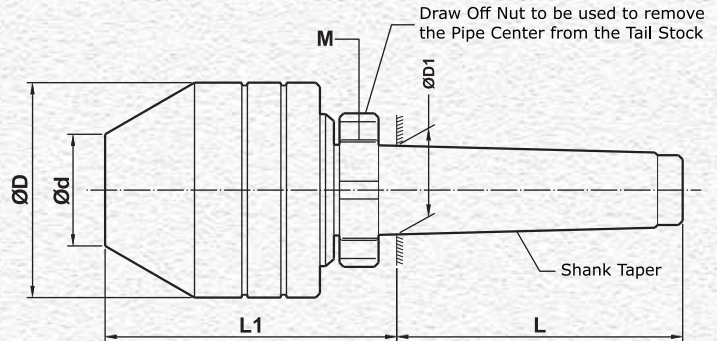

Part No.	Shank Taper	Ød mm	ØD mm	ØD1 mm	L mm	L1 mm	Max. Job Wt. Kg.	Conc. Error mm	Max. RPM
CPC MT3 40-75	MT-3	40	75	23.825	81.0	99.5	150	0.012	3500
CPC MT4 40-75	MT-4	40	75	31.267	102.5	103.0	200	0.012	3500
CPC MT5 40-75	MT-5	40	75	44.399	129.5	103.0	300	0.012	3500
CPC MT3 50-100	MT-3	50	100	23.825	81.0	106.0	200	0.012	2250
CPC MT4 50-100	MT-4	50	100	31.267	102.5	111.5	300	0.012	2250
CPC MT5 50-100	MT-5	50	100	44.399	129.5	109.5	400	0.012	2250
CPC MT4 65-125	MT-4	65	125	31.267	102.5	118.5	400	0.015	1750
CPC MT5 65-125	MT-5	65	125	44.399	129.5	119.5	500	0.015	1750
CPC MT6 65-125	MT-6	65	125	63.348	182	123.0	800	0.015	1750
CPC MT4 75-160	MT-4	75	160	31.267	102.5	134.5	500	0.015	1250
CPC MT5 75-160	MT-5	75	160	44.399	129.5	135.5	700	0.015	1250
CPC MT6 75-160	MT-6	75	160	63.348	182	139.0	1000	0.015	1250

# PIPE CENTER - BLUNT

## 60° Angle Revolving Cone (Not Dead)

(For Conventional Slow Speed  
Non CNC Application)

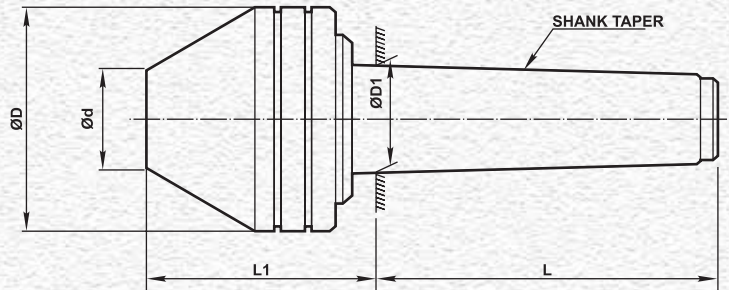

Part No.	Shank Taper	Ød mm	ØD mm	ØD1 mm	L mm	L1 mm	Conc. Error mm	Max. RPM
PC MT2 25-50	MT-2	25	55	17.780	64.0	65.0	0.015	750
PC MT2 30-65	MT-2	30	65	17.780	64.0	66.0	0.015	750
PC MT2 40-75	MT-2	40	77	17.780	64.0	69.0	0.015	600
PC MT3 25-50	MT-3	25	55	23.825	81.0	65.0	0.015	750
PC MT3 30-65	MT-3	30	65	23.825	81.0	66.0	0.015	750
PC MT3 40-75	MT-3	40	77	23.825	81.0	69.0	0.015	600
PC MT3 50-90	MT-3	50	90	23.825	81.0	70.0	0.015	600
PC MT3 65-100	MT-3	65	102	23.825	81.0	70.0	0.015	500
PC MT3 35-125	MT-3	35	127	23.825	81.0	133.5	0.015	350
PC MT3 75-125	MT-3	75	127	23.825	102.5	98.5	0.015	350

Part No.	Shank Taper	Ød mm	ØD mm	ØD1 mm	L mm	L1 mm	Conc. Error mm	Max. RPM
PC MT4 25-50	MT-4	25	55	31.267	102.5	67.5	0.015	750
PC MT4 30-65	MT-4	30	65	31.267	102.5	68.5	0.015	750
PC MT4 40-75	MT-4	40	77	31.267	102.5	70.5	0.015	600
PC MT4 50-90	MT-4	50	90	31.267	102.5	71.5	0.015	600
PC MT4 65-100	MT-4	65	102	31.267	102.5	71.5	0.015	500
PC MT4 35-125	MT-4	35	127	31.267	102.5	128.0	0.015	350
PC MT4 75-125	MT-4	75	127	31.267	102.5	93.0	0.015	350
PC MT4 75-150	MT-4	75	153	31.267	102.5	98.0	0.015	300
PC MT4 100-175	MT-4	100	178	31.267	102.5	128.0	0.015	250
PC MT4 100-200	MT-4	100	204	31.267	102.5	128.0	0.015	250
PC MT5 25-50	MT-5	25	55	44.399	129.5	67.5	0.015	750
PC MT5 30-65	MT-5	30	65	44.399	129.5	68.5	0.015	750
PC MT5 40-75	MT-5	40	77	44.399	129.5	71.5	0.015	600
PC MT5 50-90	MT-5	50	90	44.399	129.5	72.5	0.015	600
PC MT5 65-100	MT-5	65	102	44.399	129.5	72.5	0.015	500
PC MT5 35-125	MT-5	35	127	44.399	129.5	129.5	0.015	350
PC MT5 75-125	MT-5	75	127	44.399	129.5	94.5	0.015	350
PC MT5 75-150	MT-5	75	153	44.399	129.5	99.0	0.015	300
PC MT5 100-175	MT-5	100	178	44.399	129.5	128.0	0.015	250
PC MT5 100-200	MT-5	100	204	44.399	129.5	128.0	0.015	250
PC MT5 100-230	MT-5	100	231	44.399	129.5	145.0	0.015	200
PC MT6 65-100	MT-6	65	102	63.348	182.0	85.0	0.015	500
PC MT6 35-125	MT-6	35	127	63.348	182.0	131	0.015	350
PC MT6 75-125	MT-6	75	127	63.348	182.0	96.0	0.015	350
PC MT6 75-150	MT-6	75	153	63.348	182.0	101.0	0.015	300
PC MT6 100-175	MT-6	100	178	63.348	182.0	123.5	0.015	250
PC MT6 100-200	MT-6	100	204	63.348	182.0	123.5	0.015	250
PC MT6 100-230	MT-6	100	231	63.348	182.0	140.0	0.015	200
PC MT6 200-275	MT-6	200	275	63.348	182.0	130.0	0.015	150

# PIPE CENTER - POINTED

## 60° Angle Revolving Cone (Not Dead)

(For Conventional Slow Speed  
Non CNC Application)

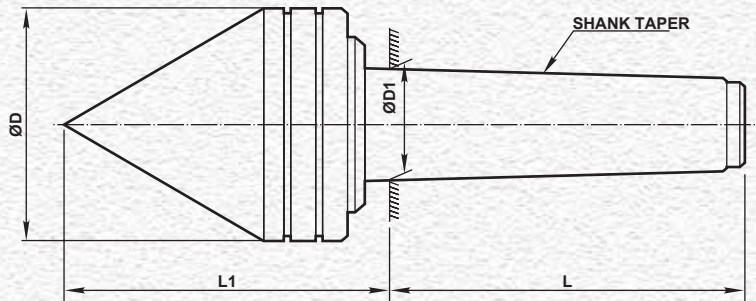

Part No.	Shank Taper	ØD mm	ØD1 mm	L mm	L1 mm	Conc. Error mm	Max. RPM
PC MT2 0-2"	MT-2	55	17.780	64.0	88.0	0.015	750
PC MT2 0-2 1/2"	MT-2	65	17.780	64.0	91.0	0.015	750
PC MT2 0-3"	MT-2	77	17.780	64.0	102.0	0.015	600
PC MT3 0-2"	MT-3	55	23.825	81.0	88.0	0.015	750
PC MT3 0-2 1/2"	MT-3	65	23.825	81.0	91.0	0.015	750
PC MT3 0-3"	MT-3	77	23.825	81.0	102.0	0.015	600
PC MT3 0-3 1/2"	MT-3	90	23.825	81.0	115.0	0.015	600
PC MT3 0-4"	MT-3	102	23.825	81.0	115.0	0.015	500
PC MT3 0-5"	MT-3	127	23.825	81.0	163.5	0.015	350
PC MT4 0-2"	MT-4	55	31.267	102.5	90.5	0.015	750
PC MT4 0-2 1/2"	MT-4	65	31.267	102.5	93.5	0.015	750
PC MT4 0-3"	MT-4	77	31.267	102.5	103.5	0.015	600
PC MT4 0-3 1/2"	MT-4	90	31.267	102.5	116.5	0.015	600
PC MT4 0-4"	MT-4	102	31.267	102.5	116.5	0.015	500
PC MT4 0-5"	MT-4	127	31.267	102.5	158.0	0.015	350
PC MT5 0-2"	MT-5	55	44.399	129.5	90.5	0.015	750
PC MT5 0-2 1/2"	MT-5	65	44.399	129.5	93.5	0.015	750
PC MT5 0-3"	MT-5	77	44.399	129.5	104.5	0.015	600
PC MT5 0-3 1/2"	MT-5	90	44.399	129.5	117.5	0.015	600
PC MT5 0-4"	MT-5	102	44.399	129.5	117.5	0.015	500
PC MT5 0-5"	MT-5	127	44.399	129.5	159.0	0.015	350
PC MT6 0-4"	MT-6	102	63.348	182.0	130.0	0.015	500
PC MT6 0-5"	MT-6	127	63.348	182.0	161.0	0.015	350

# TURRET SLEEVE UNIVERSAL MODEL (Cylindrical Bore)

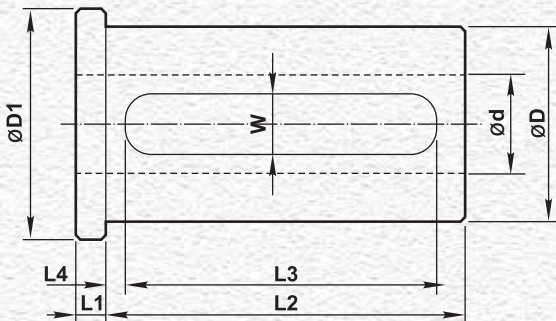

FIG. 1

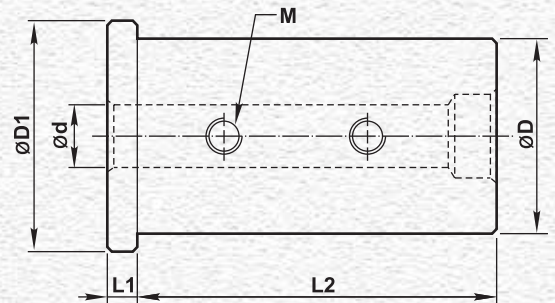

FIG. 2



Part No.	OD ØD mm	Bore Ød mm	ØD1 mm	W mm	L1 mm	L2 mm	L3 mm	L4 mm	M Thread	Fig.
TSL 16x8	16	8	22	-	5	40	-	-	M4	2
TSL 16x10	16	10	22	7	5	40	32	3	-	1
TSL 20x8	20	8	26	-	5	50	-	-	M5	2
TSL 20x10	20	10	26	-	5	50	-	-	M5	2
TSL 20x12	20	12	26	9	5	50	42	3	-	1
TSL 25x8	25	8	32	-	5	50	-	-	M6	2
TSL 25x10	25	10	32	-	5	50	-	-	M6	2
TSL 25x12	25	12	32	-	5	50	-	-	M6	2
TSL 25x16	25	16	32	10	5	50	42	3	-	1
TSL 25x20	25	20	32	10	5	50	42	3	-	1
TSL 32x8	32	8	38	-	5	60	-	-	M6	2
TSL 32x10	32	10	38	-	5	60	-	-	M8	2
TSL 32x12	32	12	38	-	5	60	-	-	M8	2
TSL 32x16	32	16	38	10	5	60	52	3	-	1
TSL 32x20	32	20	38	10	5	60	52	3	-	1
TSL 32x25	32	25	38	10	5	60	52	3	-	1
TSL 40x8	40	8	48	-	5	85	-	-	M6	2
TSL 40x10	40	10	48	-	5	85	-	-	M8	2
TSL 40x12	40	12	48	-	5	85	-	-	M8	2
TSL 40x16	40	16	48	12	5	85	77	2	-	1
TSL 40x20	40	20	48	12	5	85	77	2	-	1
TSL 40x25	40	25	48	12	5	85	77	2	-	1
TSL 40x32	40	32	48	12	5	85	77	2	-	1
TSL 50x10	50	10	-	-	8	92	-	-	M8	2
TSL 50x12	50	12	58	-	8	92	-	-	M8	2
TSL 50x16	50	16	58	12	8	92	80	4	-	1
TSL 50x20	50	20	58	12	8	92	80	4	-	1
TSL 50x25	50	25	58	12	8	92	80	4	-	1
TSL 50x32	50	32	58	12	8	92	80	4	-	1
TSL 50x40	50	40	58	12	8	92	80	4	-	1

# TURRET SOCKET

(Morse Taper Bore)



Available Sizes

OD mm	ID Morse Taper	Overall Length mm
Ø 25	MT-1	80
Ø 25	MT-2	92
Ø 32	MT-1	76
Ø 40	MT-1	90
Ø 40	MT-2	90
Ø 40	MT-4	142
Ø 50	MT-1	100
Ø 50	MT-2	100
Ø 50	MT-3	115
Ø 50	MT-4	142



Available Sizes

OD mm	ID Morse Taper	Overall Length mm
Ø 32	MT-2	75
Ø 32	MT-3	95
Ø 40	MT-3	95

# BALANCED TOOL HOLDERS ON HAIMER GERMANY ELECTRONIC BALANCING MACHINE



Balance Quality :  
G6.3@ 15000 rpm

Taper Angle  
AT-3 Class

- Balance Quality G6.3@12,000/15,000/18,000 or better
- Balancing Report available against request
- Taper Angle accuracy AT-3 Class

B  
A  
L  
A  
N  
C  
I  
N  
G  
  
R  
E  
P  
O  
R  
T

<b>HAIMER</b> TD 2009 - int PC 1/16 11/16 01/16	
	
Balancing report	
Date: 14.11.2012 Customer: Turnmax-Industria Espana Operator: Andres Torralba Order Number: 97 0000 0000	
Tolerance provided: Balancing quality: G 6.3 Balancing speed: 15000 rpm Balancing tolerance: 0.2 mg Balancing accuracy: 0.001 g/mm	
Acceptable residual unbalance: 0.2 g/mm Residual weight: 0.001 kg	
Date: <input type="text"/> Unbalance: 0.2 g/mm 137 g/1" Good	
Date: <input type="text"/> Date of control tolerance: Good	

# COLLET CHUCK

## BT TAPER

(For ER Collet)

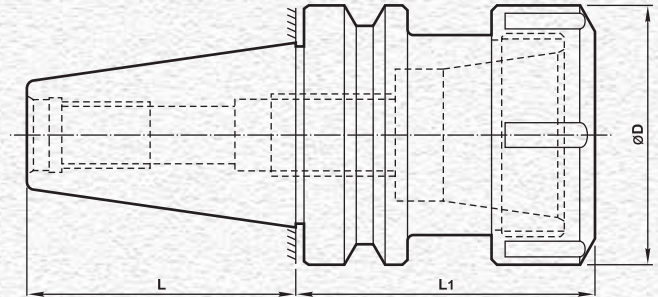

Part No.	Shank Taper	Suitable Collet	L1 mm	L mm	ØD mm	Nut
CC BT 40 ER 16x70	BT-40	ER-16	70	65.4	28	Hex. Type
CC BT 40 ER 16x100	BT-40	ER-16	100	65.4	28	Hex. Type
CC BT 40 ER 16x150	BT-40	ER-16	150	65.4	28	Hex. Type
CC BT 40 ER 20x70	BT-40	ER-20	70	65.4	34	Hex. Type
CC BT 40 ER 25x70	BT-40	ER-25	70	65.4	42	Round Type
CC BT 40 ER 32x70	BT-40	ER-32	70	65.4	50	Round Type
CC BT 40 ER 32x120	BT-40	ER-32	120	65.4	50	Round Type
CC BT 40 ER 40x80	BT-40	ER-40	80	65.4	63	Round Type
CC BT 40 ER 40x120	BT-40	ER-40	120	65.4	63	Round Type
CC BT 50 ER 32x90	BT-50	ER-32	90	101.8	50	Round Type
CC BT 50 ER 32x125	BT-50	ER-32	125	101.8	50	Round Type
CC BT 50 ER 40x90	BT-50	ER-40	90	101.8	63	Round Type
CC BT 50 ER 40x125	BT-50	ER-40	125	101.8	63	Round Type

\* Longer lengths of extension L1 also available refer website

\* Also available in BT-30 Taper

# COLLET CHUCK

ISO Taper

(For ER Collet)

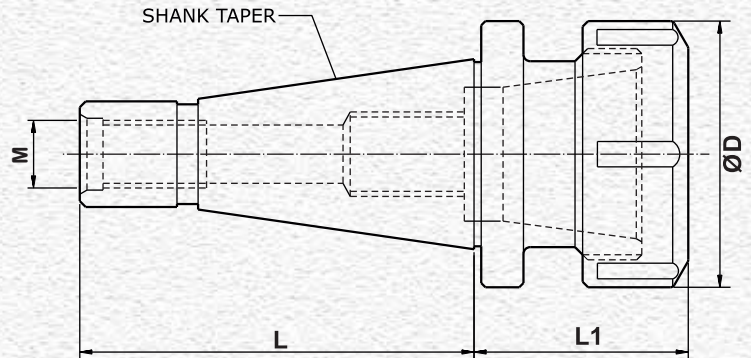

Part No.	Shank Taper	Suitable Collet	ØD mm	L mm	L1 mm	M	Nut
CC ISO 30 ER32	ISO-30	ER-32	50	68.4	54	M12	Round Type
CC ISO 30 ER40	ISO-30	ER-40	63	68.4	83	M12	Round Type
CC ISO 40 ER32	ISO-40	ER-32	50	93.4	50	M16	Round Type
CC ISO 40 ER40	ISO-40	ER-40	63	93.4	55	M16	Round Type
CC ISO 50 ER32	ISO-50	ER-32	50	126.8	58	M24	Round Type
CC ISO 50 ER40	ISO-40	ER-40	63	126.8	58	M24	Round Type

# SIDE LOCK HOLDER BT TAPER

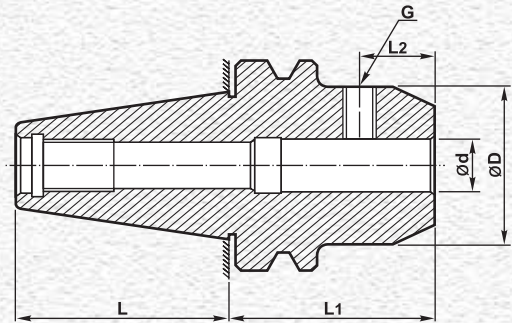

FIG. 1

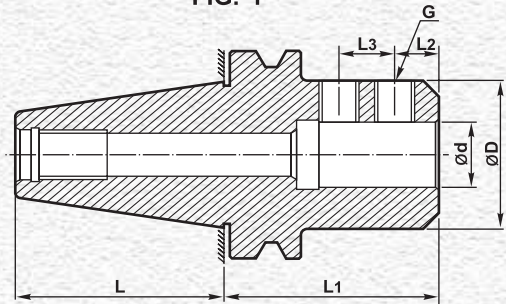

FIG. 2

Part No.	Shank Taper	Bore Ød mm	ØD mm	L mm	L1 mm	L2 mm	L3 mm	G	Fig.
SLH BT40x12	BT-40	12	42	65.4	63	22.0	-	M10	1
SLH BT40x16	BT-40	16	48	65.4	63	23.5	-	M12	1
SLH BT40x20	BT-40	20	52	65.4	63	24.5	-	M16	1
SLH BT40x25SL	BT-40	25	50	65.4	90	25.0	20	M10	2
SLH BT40x32SL	BT-40	32	60	65.4	90	30	20	M10	2
SLH BT40x40SL	BT-40	40	60	65.4	90	30	20	M10	2
SLH BT50x12	BT-50	12	42	101.8	80	22.0	-	M10	1
SLH BT50x16	BT-50	16	48	101.8	80	23.5	-	M12	1
SLH BT50x20	BT-50	20	52	101.8	80	24.5	-	M16	1
SLH BT50x25	BT-50	25	65	101.8	100	23.5	25	M16	2
SLH BT50x32	BT-50	32	72	101.8	105	23.5	28	M16	2
SLH BT50x40	BT-50	40	90	101.8	120	30	32	N20	2
SLH BT50x50	BT-50	50	95	101.8	130	32	35	M20	2

\* Also available in BT-30 Taper

# STUB MILLING ARBOUR

## BT TAPER

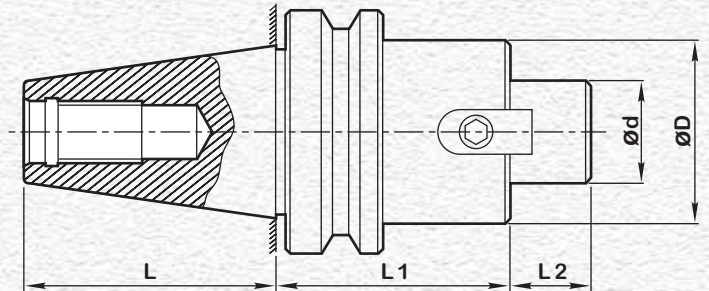

- For Cutter diameters less than 160 mm.
- For Cutter diameters more than 160 mm use Flange Type Face Mill Arbours.
- Also called Face Mill Arbour.

Part No.	Shank Taper	Cutter Bore Diameter Ød mm	L1 mm	L mm	L2 mm	ØD mm
FMA BT40x16-50	BT-40	16	50	65.4	17	32
FMA BT40x16-90	BT-40	16	90	65.4	17	32
FMA BT40x22-50	BT-40	22	50	65.4	19	40
FMA BT40x22-90	BT-40	22	90	65.4	19	40
FMA BT40x27-60	BT-40	27	60	65.4	21	48
FMA BT40x27-90	BT-40	27	90	65.4	21	48
FMA BT40x32-70	BT-40	32	70	65.4	24	58
FMA BT40x32-100	BT-40	32	100	65.4	24	58
FMA BT40x40-70	BT-40	40	70	65.4	27	68
FMA BT40x40-100	BT-40	40	100	65.4	27	68
FMA BT50x16-60	BT-50	16	60	101.8	17	32
FMA BT50x16-105	BT-50	16	105	101.8	17	32
FMA BT50x16-160	BT-50	16	160	101.8	17	32
FMA BT50x22-60	BT-50	22	60	101.8	19	40
FMA BT50x22-105	BT-50	22	105	101.8	19	40
FMA BT50x22-160	BT-50	22	160	101.8	19	40
FMA BT50x27-60	BT-50	27	60	101.8	21	48
FMA BT50x27-105	BT-50	27	105	101.8	21	48
FMA BT50x27-160	BT-50	27	160	101.8	21	48
FMA BT50x32-75	BT-50	32	75	101.8	24	58
FMA BT50x32-105	BT-50	32	105	101.8	24	58
FMA BT50x32-160	BT-50	32	160	101.8	24	58
FMA BT50x40-75	BT-50	40	75	101.8	27	70
FMA BT50x40-105	BT-50	40	105	101.8	27	70
FMA BT50x40-160	BT-50	40	160	101.8	27	70

\* Also available in BT-30 Taper



# REDUCTION SOCKETS

## BT TAPER

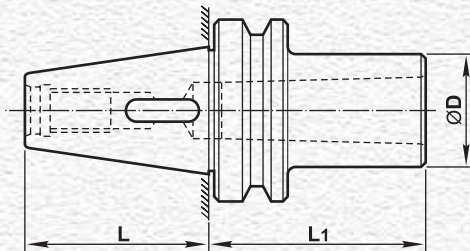

**STANDARD FIG. 1**

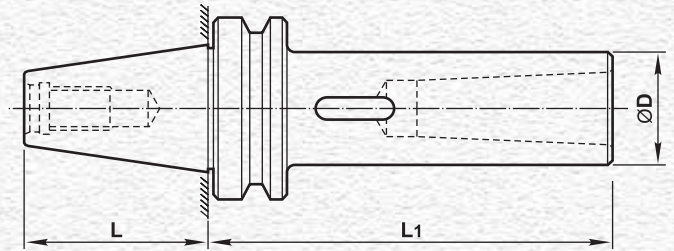

**EXTENDED FIG. 2**

- For Morse Taper (MT) tools with Tanged End Only.
- Not Suitable for Morse Taper (MT) tools with plain end or tapped end (drawbolt type).

Part No.	Shank Taper	Bore	L1 mm	L mm	ØD mm	Fig.
MRS BT40 MT1x45	BT-40	MT-1	45	65.4	25	1
MRS BT40 MT1x120	BT-40	MT-1	120	65.4	25	2
MRS BT40 MT2x60	BT-40	MT-2	60	65.4	32	1
MRS BT40 MT2x120	BT-40	MT-2	120	65.4	32	2
MRS BT40 MT3x75	BT-40	MT-3	75	65.4	40	1
MRS BT40 MT3x145	BT-40	MT-3	145	65.4	40	2
MRS BT40 MT4x95	BT-40	MT-4	95	65.4	48	1
MRS BT40 MT4x170	BT-40	MT-4	170	65.4	48	2
MRS BT50 MT1x45	BT-50	MT-1	45	101.8	25	1
MRS BT50 MT1x120	BT-50	MT-1	120	101.8	25	2
MRS BT50 MT2x45	BT-50	MT-2	45	101.8	32	1
MRS BT50 MT2x135	BT-50	MT-2	135	101.8	32	2
MRS BT50 MT3x60	BT-50	MT-3	60	101.8	40	1
MRS BT50 MT3x155	BT-50	MT-3	155	101.8	40	2
MRS BT50 MT4x85	BT-50	MT-4	85	101.8	48	1
MRS BT50 MT4x180	BT-50	MT-4	180	101.8	48	2
MRS BT50 MT5x105	BT-50	MT-5	105	101.8	63	1
MRS BT50 MT5x220	BT-50	MT-5	220	101.8	63	2
MRS BT50 MT6x275	BT-50	MT-6	275	101.8	85	2

\* Also available in BT-30 Taper

# CYLINDRICAL SHANK COLLET CHUCK

(For ER Collet)

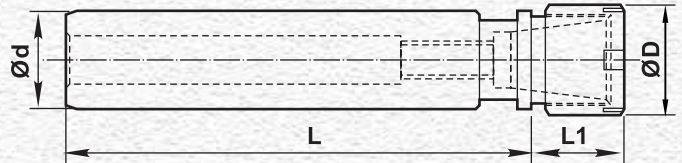

FIG. 1 : With M Type Nut

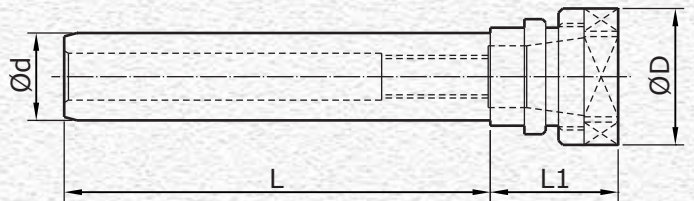

FIG. 2 : With Hex. Type Nut

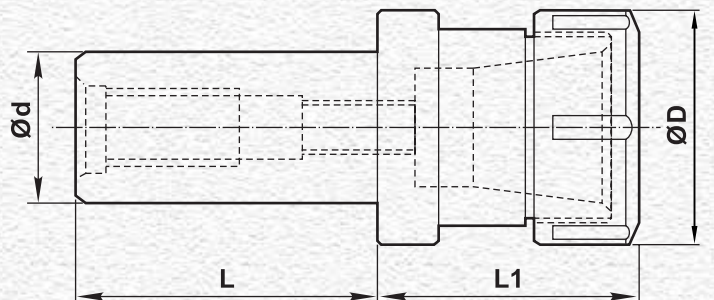
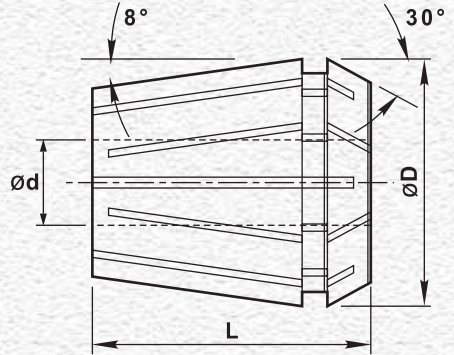

FIG. 3 : With Round Type Nut

Part No.	Ød mm	ØD mm	L mm	L1 mm	Suitable Collet	Nut	Fig.
CSCC 16xER11Mx60L	16	16	60	16.5	ER-11	M-Type	1
CSCC 16xER11Mx100L	16	16	100	16.5	ER-11	M-Type	1
CSCC 16xER11Mx150L	16	16	150	16.5	ER-11	M-Type	1
CSCC 16xER11Hx60L	16	19	60	16.5	ER-11	Hex. Type	2
CSCC 16xER16Hx60L	16	28	60	38.5	ER-16	Hex. Type	2
CSCC 16xER16Hx100L	16	28	100	38.5	ER-16	Hex. Type	2
CSCC 16xER16Hx150L	16	28	150	38.5	ER-16	Hex. Type	2
CSCC 20xER16Mx60L	20	22	60	25.5	ER-16	M-Type	1
CSCC 20xER16Mx100L	20	22	100	25.5	ER-16	M-Type	1
CSCC 20xER16Mx150L	20	22	150	25.5	ER-16	M-Type	1
CSCC 20xER20Hx60L	20	34	60	38.5	ER-20	Hex. Type	2
CSCC 20xER20Hx100L	20	34	100	38.5	ER-20	Hex. Type	2
CSCC 20xER20Hx150L	20	34	150	38.5	ER-20	Hex. Type	2
CSCC 25xER20Mx60L	25	28	60	27.5	ER-20	M-Type	1
CSCC 25xER20Mx100L	25	28	100	27.5	ER-20	M-Type	1
CSCC 25xER20Mx150L	25	28	150	27.5	ER-20	M-Type	1
CSCC 25xER20Hx100L	25	34	100	25.5	ER-20	Hex. Type	2
CSCC 25xER25Rx60L	25	42	60	53	ER-25	Round Type	3
CSCC 32xER25Mx60L	32	35	60	28.0	ER-25	M-Type	1
CSCC 32xER25Mx100L	32	35	100	28.0	ER-25	M-Type	1
CSCC 32xER25Mx150L	32	35	150	28.0	ER-25	M-Type	1
CSCC 32xER16Hx65L	32	28	65	46	ER-16	Hex. Type	2
CSCC 32xER20Hx65L	32	34	65	45.5	ER-20	Hex. Type	2
CSCC 32xER25Rx65L	32	42	65	53	ER-25	Round Type	3
CSCC 32xER32Rx65L	32	50	65	61.0	ER-32	Round Type	3
CSCC 40xER20Hx85L	40	34	85	47.5	ER-20	Hex. Type	2
CSCC 40xER25Rx85L	40	42	85	55	ER-25	Round Type	3
CSCC 40xER32Rx85L	40	50	85	53.0	ER-32	Round Type	3
CSCC 40xER40Rx85L	40	63	85	62.0	ER-40	Round Type	3

# ER COLLETS (DIN 6499)



Size	Bore Range Ød	ØD mm	L mm	Part No. Example
ER-11	2 to 7 mm in steps of 0.5mm	11.5	18.0	ER11 5 mm
ER-16	2 to 10 mm in steps of 1mm	17	27.5	ER16 8 mm
ER-20	2 to 13 mm in steps of 1mm	21	31.5	ER20 8 mm
ER-25	2 to 16 mm in steps of 1mm	26	34.5	ER25 8 mm
ER-32	3 to 20 mm in steps of 1mm 1/4" to 3/4" in steps of 1/16"	33	40.0	ER32 8 mm
ER-40	4 to 26 mm in steps of 1mm 1/4" to 1" in steps of 1/16"	41	46.0	ER40 8 mm

# NUT FOR ER COLLETS

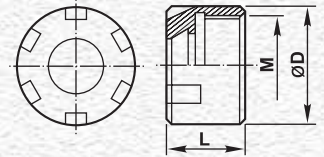
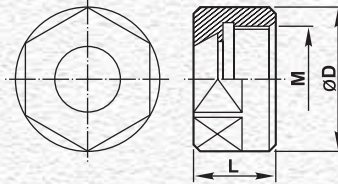
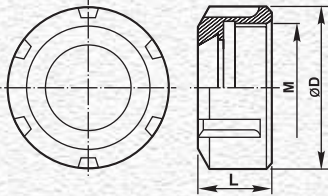

**STANDARD (ROUND TYPE SLOTTED)**  
**FIG. 1**

**HEX TYPE**  
**FIG. 2**

**M TYPE**  
**FIG. 3**

Part No.	TYPE	ØD mm	L mm	M	Fig.
NUT ER11M	Mini	16	12.0	M13 x 0.75	3
NUT ER11H	Hexagonal	19	12	M14 x 0.75	1
NUT ER16M	Mini	22	18.0	M19 x 1	3
NUT ER20M	Mini	28	19.5	M24 x 1	3
NUT ER25M	Mini	35	20.0	M30 x 1	3
NUT ER16H	Hexagonal	28	17.5	M22 x 1.5	2
NUT ER20H	Hexagonal	34	19.0	M25 x 1.5	2
NUT ER25R	Round & Slotted	42	20.0	M32 x 1.5	1
NUT ER32R	Round & Slotted	50	22.5	M40 x 1.5	1
NUT ER40R	Round & Slotted	63	25.5	M50 x 1.5	1

# PULL STUD FOR BT TAPER

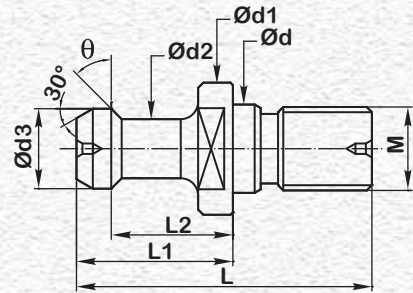
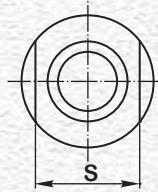
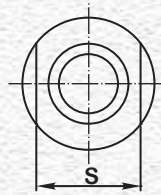

FIG. 1

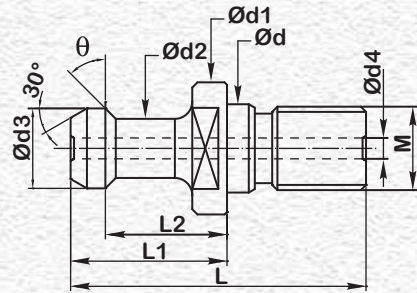
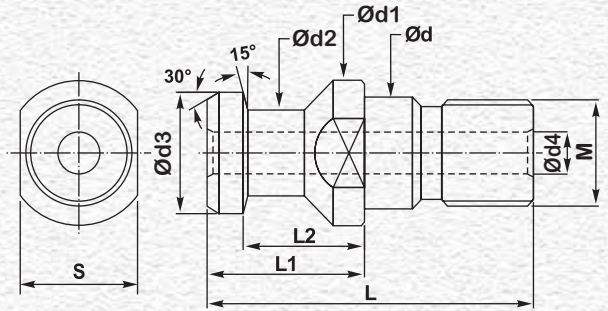

FIG. 2

Part No.	Suitable for Taper	Angle $\theta$	M	$\varnothing d$ mm	$\varnothing d1$ mm	$\varnothing d2$ mm	$\varnothing d3$ mm	$\varnothing d4$ mm	L1 mm	L2 mm	L mm	S mm	Fig.
PS BT40 45°	BT-40	45°	M16	17	23	10	15	-	35	28	60	19	1
PS BT40 45° CH	BT-40	45°	M16	17	23	10	15	4	35	28	60	19	2
PS BT40 60°	BT-40	60°	M16	17	23	10	15	-	35	28	60	19	1
PS BT40 60° CH	BT-40	60°	M16	17	23	10	15	4	35	28	60	19	2
PS BT40 90°	BT-40	90°	M16	17	23	10	15	-	35	28	60	19	1
PS BT40 90° CH	BT-40	90°	M16	17	23	10	15	4	35	28	60	19	2
PS BT50 45°	BT-50	45°	M24	25	38	17	23	-	45	35	85	30	1
PS BT50 45° CH	BT-50	45°	M24	25	38	17	23	6	45	35	85	30	2
PS BT50 60°	BT-50	60°	M24	25	38	17	23	-	45	35	85	30	1
PS BT50 60° CH	BT-50	60°	M24	25	38	17	23	6	45	35	85	30	2
PS BT50 90°	BT-50	90°	M24	25	38	17	23	-	45	35	85	30	1
PS BT50 90° CH	BT-50	90°	M24	25	38	17	23	6	45	35	85	30	2

\* Also available for BT-30 Taper

# PULL STUD FOR SK TAPER (DIN 69872)



FORM: A

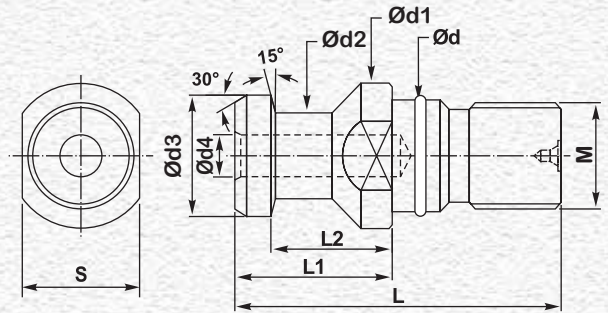

FORM: B

Part No.	Suitable for Taper	Form	M	Ød mm	Ød1 mm	Ød2 mm	Ød3 mm	Ød4 mm	L1 mm	L2 mm	L mm	S mm
PS SK40 A	SK-40	A	M16	17	23	14	19	7.0	26	20	54	19
PS SK40 B	SK-40	B	M16	17	23	14	19	7.0	26	20	54	19
PS SK50 A	SK-50	A	M24	25	36	21	28	11.5	34	25	74	30
PS SK50 B	SK-50	B	M24	25	36	21	28	11.5	34	25	74	30



# INTEGRAL SHANK KEYLESS DRILL CHUCK

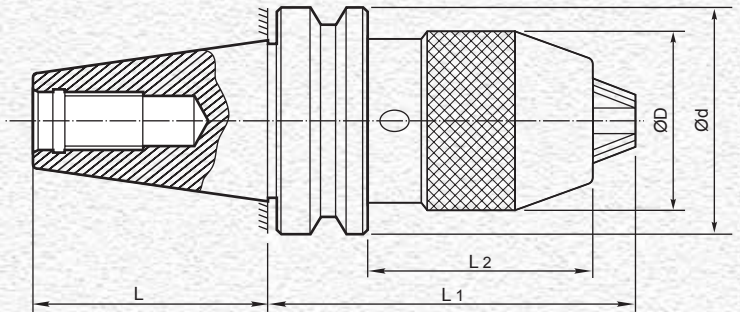

# One piece construction ensures higher rigidity & better safety.

Part No.	Shank Taper	Chuck Size	L mm	L1 mm	L2 mm	ØD mm	Ød mm	Runout (at 25 mm)
KLDC ISBT 40 1-13	BT-40	1-13 mm	65.4	105.5	66	50	63	0.050mm
KLDC ISBT 50 1-13	BT-50	1-13 mm	101.8	117.5	66	50	63	0.050mm

# KEYLESS DRILL CHUCK

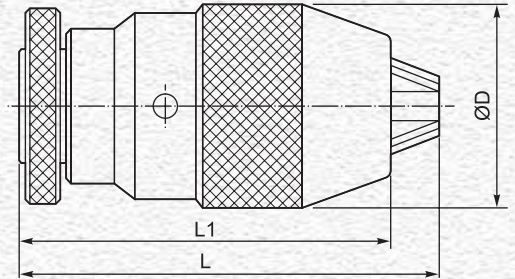

- Wipe off the antirust oil applied on both the Keyless Chuck female taper and Drill Chuck Arbour male taper with MTO or kerosene before assembling them together. Do not hammer or use press machine to lock the drill chuck arbour & keyless chuck. This would distort the chuck beyond repair.
- For right hand rotation application only.

Part No.	Model	Size mm	L mm	L1 mm	D mm	Runout (at 25 mm)
KLDC 0-6.5 HD	Heavy Duty	0-6.5	69	62	34.0	0.050 mm
KLDC 0.5-8 HD	Heavy Duty	0.5-8	78	68	37.5	0.050 mm
KLDC 1-13 HD	Heavy Duty	1-13	103	91	50.0	0.050 mm
KLDC 3-16 HD	Heavy Duty	3-16	115	102	57.0	0.050 mm
KLDC 5-20 HD	Heavy Duty	5-20	127	112	59.5	0.050 mm

Also Available



Collet Chuck in SK Taper



Collet Chuck in R8 Taper



Collet Chuck in Morse Taper  
(Draw Bolt type)



Stub Milling Arbour Flange Type  
for Cutter Dia.>160mm

Also Available



Side Lock Holder  
in SK Taper



Drill Chuck Arbour in BT Taper



CNC Lathe Head Stock Sleeve



C Hook Type  
Spanner



Multi Hook Type  
Spanner



Keyless Chuck  
Spanner



M Type  
Spanner



R.C. Wedge

# CNC DEAD CENTER PLAIN STUB With Draw Off Nut

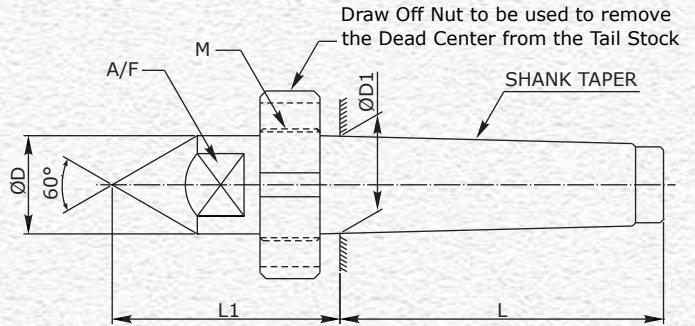

Part No.	Shank Taper	L mm	L1 mm	ØD mm	ØD1 mm	M (THREAD)	A/F mm
CNC DC MT2 PS	MT-2	64.0	48.0	18.0	17.780	M22 X 1.5	14
CNC DC MT3 PS	MT-3	81.0	57.0	24.1	23.825	M27 X 1.5	19
CNC DC MT4 PS	MT-4	102.5	72.5	31.6	31.267	M36 X 1.5	27
CNC DC MT5 PS	MT-5	129.5	87.5	44.7	44.399	M48 X 1.5	36
CNC DC MT6 PS	MT-6	182.0	108.0	63.8	63.348	M68 X 1.5	55

# CNC DEAD CENTER PLAIN EXTENDED

With Draw Off Nut

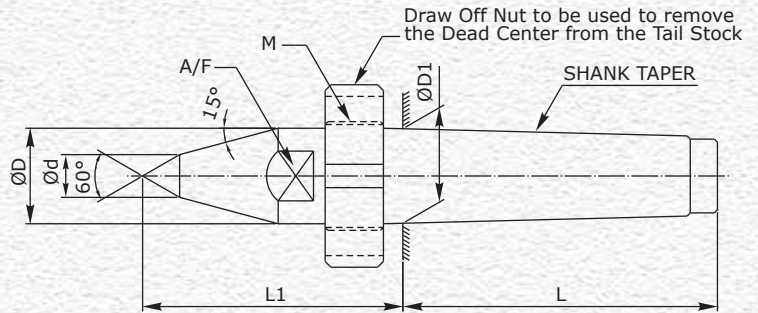

Part No.	Shank Taper	L mm	L1 mm	$\varnothing D$ mm	$\varnothing D1$ mm	$\varnothing d$ mm	M (THREAD)	A/F mm
CNC DC MT2 PE	MT-2	64.0	52.0	18.0	17.780	8	M22 X 1.5	15
CNC DC MT3 PE	MT-3	81.0	67.0	24.1	23.825	11	M27 X 1.5	21
CNC DC MT4 PE	MT-4	102.5	83.5	31.6	31.267	14	M36 X 1.5	28
CNC DC MT5 PE	MT-5	129.5	107.0	44.7	44.399	18	M48 X 1.5	40
CNC DC MT6 PE	MT-6	182.0	145.0	63.8	63.348	20	M68 X 1.5	55

# CNC DEAD CENTER CARBIDE TIPPED STUB

With Draw Off Nut

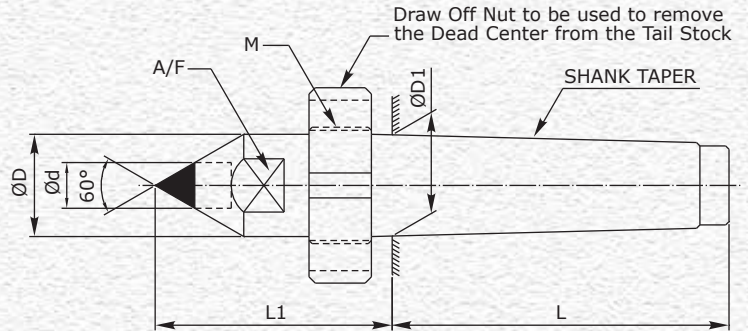

Part No.	Shank Taper	L mm	L1 mm	ØD mm	ØD1 mm	Ød mm C.T.	M (THREAD)	A/F mm
CNC DC MT2 CTS	MT-2	64.0	48.0	18.0	17.780	8	M22 X 1.5	15
CNC DC MT3 CTS	MT-3	81.0	57.0	24.1	23.825	11	M27 X 1.5	21
CNC DC MT4 CTS	MT-4	102.5	72.5	31.6	31.267	14	M36 X 1.5	28
CNC DC MT5 CTS	MT-5	129.5	87.5	44.7	44.399	18	M48 X 1.5	40
CNC DC MT6 CTS	MT-6	182.0	108.0	63.8	63.348	18	M68 X 1.5	56

# CNC DEAD CENTER CARBIDE TIPPED EXTENDED

With Draw Off Nut

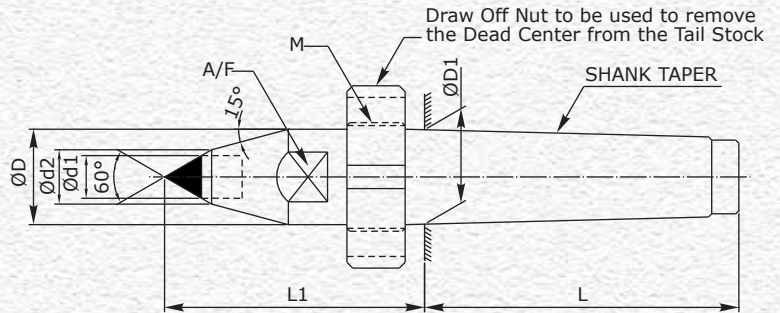

Part No.	Shank Taper	L mm	L1 mm	ØD mm	ØD1 mm	Ød1 mm C.T.	Ød2 mm	M (THREAD)	A/F mm
CNC DC MT2 CTE	MT-2	64.0	52.0	18.0	17.780	8	11	M22 X 1.5	15
CNC DC MT3 CTE	MT-3	81.0	67.0	24.1	23.825	11	14	M27 X 1.5	21
CNC DC MT4 CTE	MT-4	102.5	83.5	31.6	31.267	11	14	M36 X 1.5	28
CNC DC MT5 CTE	MT-5	129.5	107.0	44.7	44.399	14	18	M48 X 1.5	40
CNC DC MT6 CTE	MT-6	182.0	145.0	63.8	63.348	18	22	M68 X 1.5	56



# DEAD CENTER PLAIN FULL

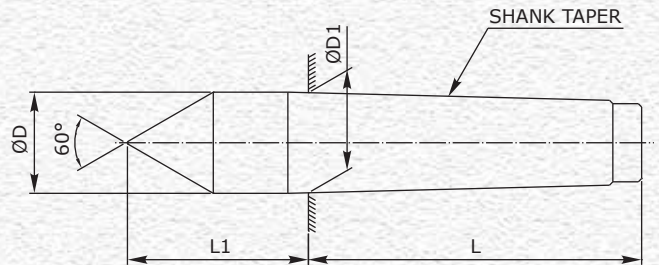

Part No.	Shank Taper	L mm	L1 mm	ØD mm	ØD1 mm
DC MT1 PF	MT-1	53.5	26.5	12.2	12.065
DC MT2 PF	MT-2	64.0	36.0	18.0	17.780
DC MT3 PF	MT-3	81.0	44.0	24.1	23.825
DC MT4 PF	MT-4	102.5	57.5	31.6	31.267
DC MT5 PF	MT-5	129.5	70.5	44.7	44.399
DC MT6 PF	MT-6	182.0	88.0	63.8	63.348

# DEAD CENTER CARBIDE TIPPED FULL STANDARD TIP

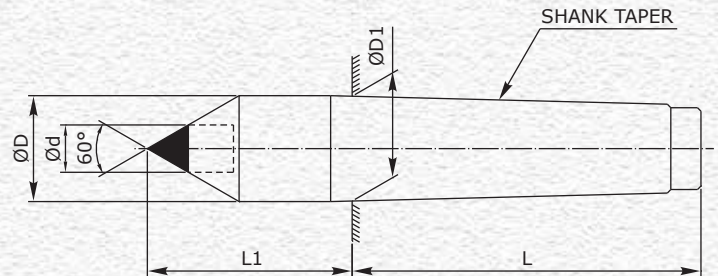

Part No.	Shank Taper	L mm	L1 mm	$\varnothing D$ mm	$\varnothing D_1$ mm	$\varnothing d$ mm C,T,
DC MT1 CTF	MT-1	53.5	26.5	12.2	12.065	5
DC MT2 CTF	MT-2	64.0	36.0	18.0	17.780	8
DC MT3 CTF	MT-3	81.0	44.0	24.1	23.825	11
DC MT4 CTF	MT-4	102.5	57.5	31.6	31.267	14
DC MT5 CTF	MT-5	129.5	70.5	44.7	44.399	18
DC MT6 CTF	MT-6	182.0	88.0	63.8	63.348	18

# DEAD CENTER CARBIDE TIPPED SPECIAL LARGER CARBIDE TIP STANDARD RANGE

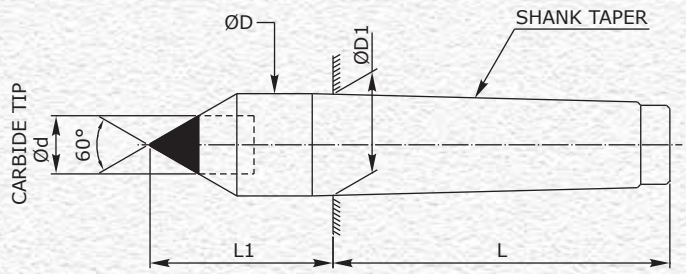

**Fig. 1**

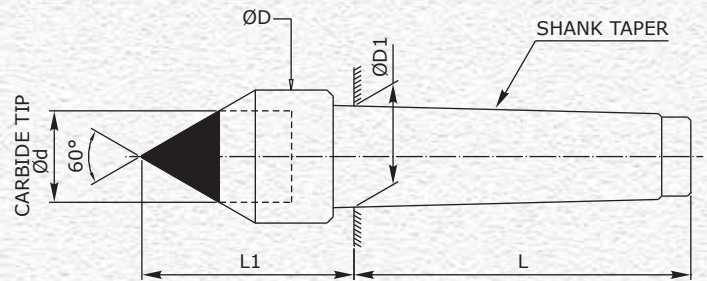

**Fig. 2**

Part No.	Shank Taper	Carbide Tip Ød mm	ØD mm	ØD1 mm	L mm	L1 mm	Fig.
DC MT2 CT AD11	MT-2	11	18.0	17.780	64.0	36.0	1
DC MT2 CT AD14	MT-2	14	24.0	17.780	64.0	43.0	2
DC MT2 CT AD18	MT-2	18	28.0	17.780	64.0	48.0	2
DC MT3 CT AD14	MT-3	14	24.1	23.825	81.0	44.0	1
DC MT3 CT AD18	MT-3	18	28.0	23.825	81.0	48.0	2
DC MT3 CT AD22	MT-3	22	32.0	23.825	81.0	51.0	2
DC MT3 CT AD25	MT-3	25	39.0	23.825	81.0	63.0	2
DC MT3 CT AD28	MT-3	28	39.0	23.825	81.0	65.0	2
DC MT4 CT AD18	MT-4	18	31.6	31.267	102.5	57.5	1
DC MT4 CT AD22	MT-4	22	31.6	31.267	102.5	57.5	1
DC MT4 CT AD25	MT-4	25	39.0	31.267	102.5	62.0	2
DC MT4 CT AD28	MT-4	28	39.0	31.267	102.5	65.0	2
DC MT4 CT AD33	MT-4	33	45.0	31.267	102.5	64.0	2
DC MT5 CT AD22	MT-5	22	44.7	44.399	129.5	70.5	1
DC MT5 CT AD25	MT-5	25	44.7	44.399	129.5	70.5	1
DC MT5 CT AD28	MT-5	28	44.7	44.399	129.5	70.5	1
DC MT5 CT AD33	MT-5	33	44.7	44.399	129.5	70.5	1
DC MT5 CT AD40	MT-5	40	56.0	44.399	129.5	75.0	2

Also Available



Carbide Tipped Dead Centre  
With Full 60° as Carbide



Blunt Carbide Dead Center  
Bull Nose Type

---

## R8 Taper Tooling



Collet Adaptor



Collet



Milling Reduction Socket



Drill Chuck Arbour

Also Available  
ISO Taper Tooling



Collet Adaptor



Milling Reduction Socket



Side Lock Holder



Stub Milling Arbour



Drill Chuck Arbour

**Also Available  
Sleeves & Sockets**



Drill Sleeve

Extension Socket

Split Sleeve

---

**Milling Collets**



Schaublin



Tail

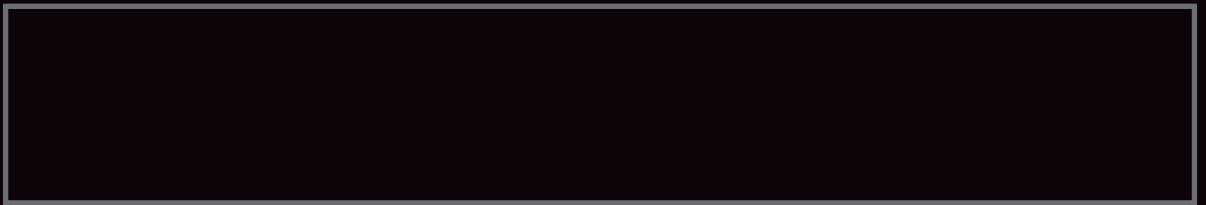

# Custom Made Tooling





## Customized Dead Pipe Centers



## Customized Dead Pipe Centers with staggered Carbide Tips



# Stub Milling Arbour Extended



# **TURNMAX MACHINE TOOLS**

---

10, Samrat Industrial Area, Near S.T. Workshop,

Gondal Road, RAJKOT - 360 004. (INDIA)

Phone : + 91 281 2376622, 2376070

E-mail : [sales@turnmax.in](mailto:sales@turnmax.in), [turnmaxsales@gmail.com](mailto:turnmaxsales@gmail.com)

Website : [www.turnmax.in](http://www.turnmax.in)

Jan. 2019